

BR-M400

Blackbody Calibration Source



Description

The BR-M400 is a rugged calibration source and suitable for use as a primary radiation source for calibration and verification of infrared thermometers.

The blackbody calibration source is designed by excellent emitter surface uniformity; and superior accuracy. The radiation surface is produced in a special black-finishing process, which guarantees a high quality and high uniformity of the surface.

Each blackbody system consists of two modules: the blackbody source and the indicator/controller. The blackbody surface consists of concentric V-shaped grooves formed on a highly conductive aluminum plate. Built-in digital temperature Indicator/controller with each unit provides accurate, stable temperatures while displaying the temperature readings of the calibration source.

1. Specification

Temperature Range : Tamb+10°C ~ 400°C	Accuracy : ± 0.5°C at 50°C ± 1.0°C at 100°C ± 1.3°C at 250°C ± 2.0°C at 400°C
Temperature resolution : 0.1°C	
Emissivity > 0.97	
Aperture : Φ70mm	Controller : PID
Warm-up time : 100°C / 30 min	Ambient Temperature : 0°C to 45°C
Temperature sensor : PT100	Fuse : 220V/5A
Power supply : 220VAC±10%, 50/60 Hz	Dimensions (L*W*H) : 220×160×260 mm
Power consumption : 350 W	Weight : 4.3 kg

2. Operation



Installation

The BR-M400 can be installed upright on any sturdy bench top or any other suitable flat and stable surface. Please take care in any case that the BR-M400 is positioned horizontal and should not be tipped on its side or turned upside down..

Switch On

After the installation of the unit you can switch on the [Power Switch] on the front side. The PID controller display will show the temperature set point [SV] and the current temperature of the black body [PV]. But the temperature indication on the controller must not be used as an accurate measurement of target plate temperature.

You can lock the control panel of the BR-M400 to avoid a non-authorized change of parameters on the unit. To lock the controller, please press the Function key [SET] for 3 seconds until LC is shown in the PV display. Then release the Function key [SET] and press the Up key or Down key to change the value in the range of 0~2 in the SV display.

- 0 All parameters can be changed
- 1 Only P, D, I and temperature set point can be changed
- 2 No change is possible

Controller Specification (preset)

P = 2

I = 88

D = 22

Setup of the Set Point Value

Please push the (\triangle) Up key or (∇) Down key to set up the desired temperature value in the lower SV display. After the desired set point is shown, the BR-M400 will start to heat up automatically.

The life expectancy of the BB depends on the time and temperature of operation. The higher the temperature, the shorter the life spans. The temperature should be gradually increased by 100°C every time to the desired/target temperature. Dependent from the difference between current black body temperature and set point value this process can take up from 15 to 45 minutes (from room temperature to 300 °C).

Power OFF

If the source has been operated at a temperature in excess of 200°C, it is important to allow the source to reduce in temperature before it is disconnected from the mains supply. Before you switch off the BR-M400, a set point temperature of 0°C [SV] must be selected. When the source temperature has fallen to below 200°C [PV], the source may be switched off. A fan is fitted to the source to keep the controller cool and also to increase the cooling rate.

WARNING

If this cooling down procedure is not followed, the controller and control circuit will overheat and damage will occur.

*Note: Read the manual carefully before the initial start-up. The producer reserves the right to change the herein described specifications in case of technical advance of the product.

3. Troubleshooting

Problem	Solution
No display after switch on	a. Check Power Cord connections. b. Check rear panel fuse(s). c. Unit requires service, contact service department.
upper display: HH	Check PT100 probe
After switch on the upper display is showing: LL and all LED are flashing	Mains voltage too low
Unit turns on but the target plate will not get hot	a. Check that you have entered a set point between Ambient+10 to 400°C b. Verify that the PID controller is set to its factory default settings. c. Unit has overheated causing the thermal reset switch to open. d. Unit requires service, contact customer service department.

4. Notice

- (1) The housing of the BR-M400 can get warm or hot. Do not put any materials or objects on the radiator housing! The ventilation outlet on the back side as well as the radiation aperture on the front must not be covered by materials or objects! Keep hands and fingers away from the target plate area.
- (2) To avoid a damage of the special coating, please do not touch the radiation surface with sharp or spiky objects. Keep the inner cavity area clean and dust free by covering the BR4 M00 when not in use.
- (3) On the top section of the black body you will find a $\Phi 6\text{mm}$ hole. You can place a 4mm thermocouple probe here for an external monitoring of the radiator temperature.
- (4) Do not connect or disconnect while power is on.
- (5) Connect the power cable to a 220VAC service that matches the power requirement.

6. Circuit Diagram

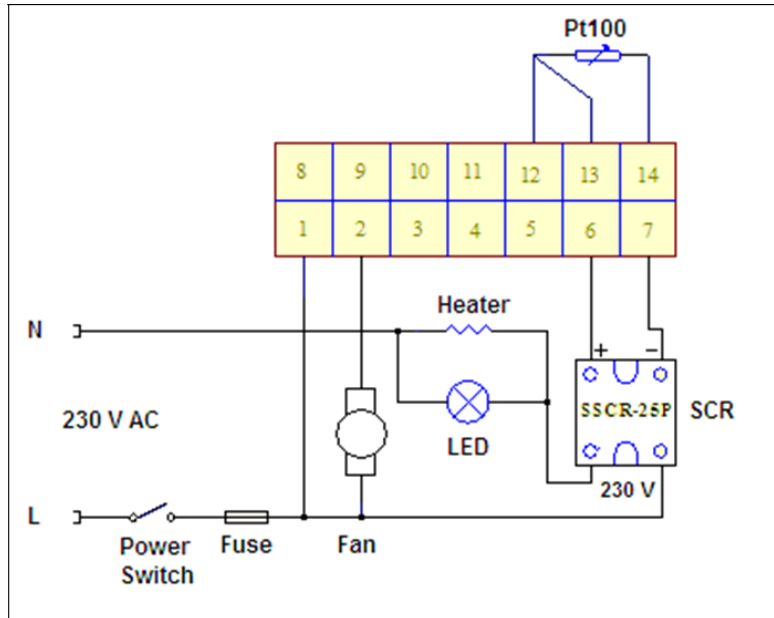

7. Package Content

- 1) BR-M400 blackbody calibration source
- 2) AC power cord
- 3) Two pieces of spare 5A fuse
- 4) Four pieces of spare tiles
- 5) Operator's manual
- 6) Test report

Warranty

Each product passes through a quality process. Nevertheless, if a failure occurs please contact the customer service at once. The period of warranty starts from the date of delivery of the product to the customer and shall cover a period of 12 months. This warranty shall not apply to fuses, batteries, or any product that has been subject to misuse, neglect, accident, or abnormal conditions of operation.

The manufacturer shall not be liable for any special, incidental or consequential damages, whether in contract, tort, or otherwise. If a failure occurs during the warranty period, the product will be replaced, calibrated or repaired without further charges. The freight costs will be paid by the sender. The manufacturer reserves the right to exchange components of the product instead of repairing it.

If the failure results from misuse, neglect, accident, or abnormal conditions of operation or storage, the user has to pay for the repair. In that case you may ask for a cost estimate beforehand.

SENTEST Instruments Corporation Ltd.
www.sentest.com